

FLORIM MAPS OF CERIM EXTRA-THICK FLOOR

New solution in extra-thick porcelain stoneware for outdoor tiling.

2 cm thick, coloured fine porcelain stoneware slabs obtained from atomizing high-class clays, quartzes and metal oxides pressed at 400 kg/ cm², completely sintered at a temperature of 1220 °C and then squared using a system of abrasive grinders.

Fields of application:

Outdoor tiling in private dwellings (gardens, terraces, patios, entrance footpaths, pools). Outdoor - indoor tiling in public premises (industrial areas, urban areas, wellness and hospitality zones, pools, public parks).

LAYING ON GRASS: (gardens, gazebos, entrance footpaths, perimeter areas of private swimming pools)

The materials can be laid easily on grass; the system can also be removed and repositioned, thereby allowing maximum flexibility in laying as it can be installed either with a minimum joint, or with a joint of 1 cm and over (Japanese joint).

Advice for installation

Remove the underlying soil in the area where you want to place the slab, to a thickness of around 5-6 cm.

Apply an evenly graded gravel bed into the area you have cleared, to a thickness of around 3-4 cm, and compact the base layer

Rest the ceramic slab on the gravel bed and tap with a rubber hammer to eliminate any unevenness.

Warnings:

Check that the surface of the slab is level with the surface of the grass, in order to avoid damage when the grass is mowed mechanically.

The system cannot be used in cases where motor vehicles and/or high dynamic loads transit.

LAYING ON GRAVEL AND SAND (courtyards, terraces, floor slabs, patios, pedestrian walkways, perimeter areas of private swimming pools)

The materials can be laid easily on sand or gravel; the system is also easy to remove and reposition, thereby allowing maximum creativity in laying the materials; the system can also be applied either with minimum joint or with the slabs arranged with a joint of at least 1 cm between the slabs

Level and compact the surface of the supporting layer (sand or gravel)

Lay the ceramic slab on the gravel or sand bed

Tap with rubber hammer to eliminate any unevenness.

Fill the joints between the slabs with gravel or sand to give the surface greater stability

Warnings:

Check that the surface of the slab is level with the surface of the gravel layer in order to avoid movements of the slab or damage through impact from the side.

The system cannot be used in cases where motor vehicles and/or high dynamic loads transit.



FLORIM CERAMICHE S.p.A. a socio unico

VIA CANALETTO 24 / 41042 FIORANO MODENESE MO ITALY / T. +39 0536 840111 / F. +39 0536 844750

WWW.FLORIM.IT / CAPITALE SOCIALE EURO 50.000.000 I.V.

ISCR. AL REG. DELLE IMPRESE DELLA C.C.I.A.A. DI MODENA / COD. FISC. E P. IVA IT 01265320364

GLUEING WITH ADHESIVE (environments subject to high static loads, pavements, courtyards, urban furnishing, vehicle access roads, garages, external anti-slip flooring, pools, wellness areas, industrial areas)

There are no special instructions other than those for lower-thickness ceramic materials; we would remind you that it is always worthwhile checking the consistency and flatness of the bed before carrying out glueing of the slab.

For laying in environments that are subject to strong static or dynamic loads we recommend glueing with Class C2 improved adhesives and double coating (on the bed and on the back of the slab);

If several sizes of tile are being laid in combination, remember that Florim provides for modularity of its products with 3 mm joints.

LAYING AS A FLOATING FLOOR (terraces, floor slabs, balconies, outdoor environments subject to pedestrian traffic)

There are currently no regulations governing requirements for ceramic material used as SELF-SUPPORTING RAISED FLOORING in outdoor environments.

With the desire to give technical instructions for use in this way, Florim has subjected its ceramic slabs to the harmonised tests required by EN 1339 standard (technical regulation on CONCRETE FLOORING SLABS).

From the results of tests carried out, the MAPS OF CERIM material exceeds the requirements laid down by EN 1339 standard for use as outdoor flooring. For greater safety and protection of the user, Florim requires a **maximum overlay height of 10 cm to be set** and the use of the feet, as in the drawing below

SIZE 60X60 cm: 1 support for each corner (1 support per slab overall)
SIZE 40X80 cm: 1 support for each corner (1 support per slab overall)

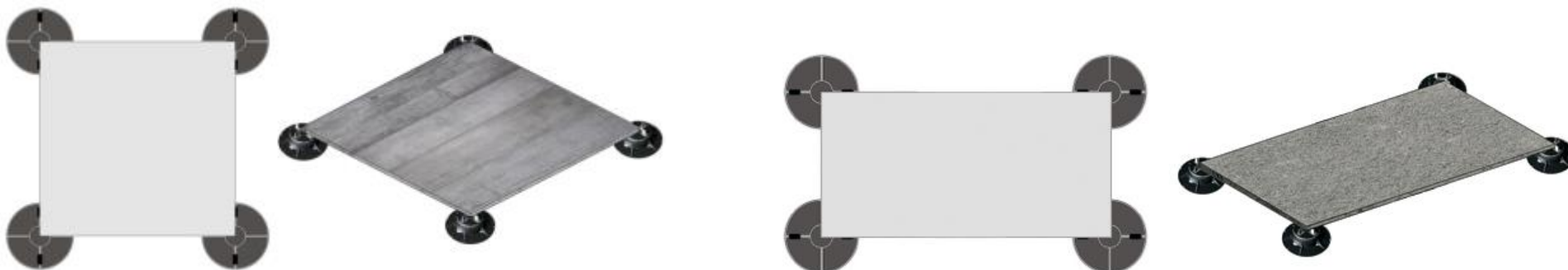

In the case of flooring for public use or where there are high loads, Florim recommends the adoption of additional supports under the slab, as in the diagram below

SIZE 60X60 cm: 1 support for each corner + one central support (2 supports per slab overall)



SIZE 40X80 cm: 1 support for each corner + one central support (2 supports per slab overall)



If a greater overlay height is required, Florim recommends glueing a backing plate or safety mesh to the back and additional supports under the slab, as in the attached diagram;

SIZE 60X60 cm: 1 support for each corner + one central support (2 supports per slab overall)

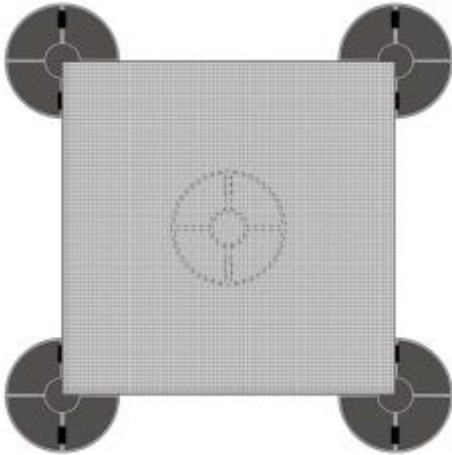

SIZE 40X80 cm: 1 support for each corner + one central support (2 supports per slab overall)

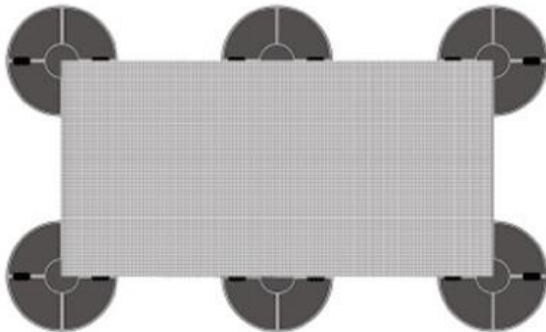

Laying instructions

Check that the underlayer is flat, compact, rigid and suitable for supporting the weight of the floor without becoming distorted.

Choose the supports that are suitable for use.

Provide for suitable sloping of the ground surface to obtain the correct drainage of rain water.

The system cannot be used in cases where high dynamic loads transit.

Technical data

VALUES MEASURED ON SIZE 60X60 CM

| | | |
|---|-------------------------|-------------|
| Bending strength | 52 Mpa (average value) | UNI EN 1339 |
| Breaking load | 14,0 KN (average value) | UNI EN 1339 |
| Determination of frost resistance (loss of mass) | 0,0 kg/m ² | UNI EN 1339 |
| Bending strength after frosting | 50 Mpa (average value) | UNI EN 1339 |
| Breaking load after frosting | 13,5 KN (average value) | UNI EN 1339 |

The data measured lead to the presumed attribution of **Class T11 for load and Class 3 for frost resistance**